

PRC-023-2 and PRC-023-3 Update

August 8, 2013

Jonathan Hayes
jhayes@spp.org · 501.614.3509

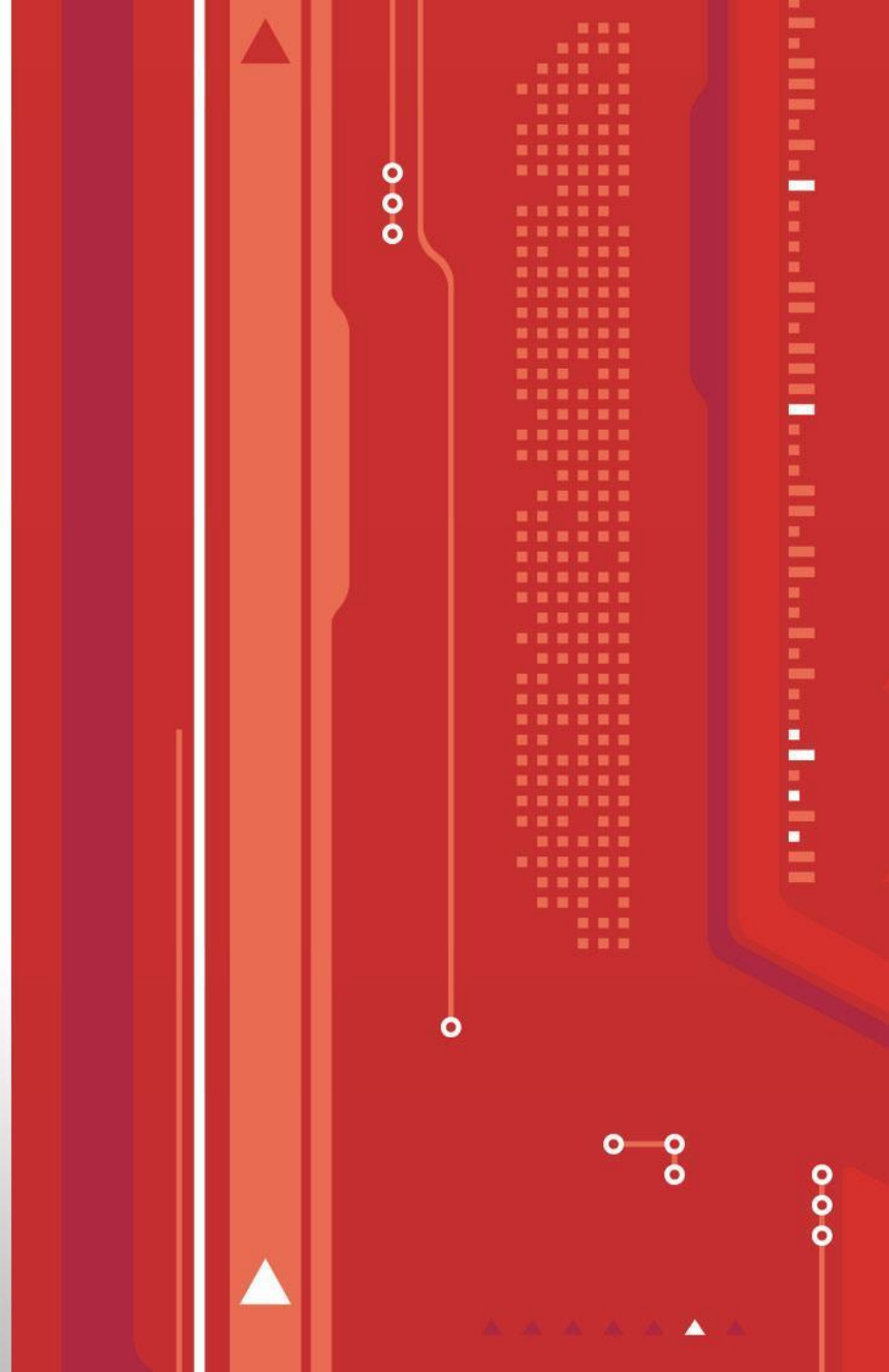

PRC 023-2 and PRC 023-3 Update

- **Upcoming Effective dates**
 - R 1-3 and R6 due dates
 - The list of circuits
 - Changing/updating the list
 - Changes from PRC 023-3
 - Considerations moving forward

R1 (Due Dates)

- **R1 – Setting 200kV & above (Based on Applicability)**
 - **Switch-on-to-fault schemes Later of 1st day of 1st quarter after regulatory approval of PRC 023-2 or 1st day of 1st quarter 39 months after regulatory approval of PRC 023-1 (October 1, 2013)**
 - **Elements identified by PC 1st day of 1st quarter 39 months after notification by the PC**
 - **Or if Elements were identified in planning horizon outside of 39 month window then it will be 1/1/xx where xx would be that year beyond 2017 in the planning horizon**

R2-R3 (Due Dates)

- **R2 – Set out-of-step blocking elements**
 - **Elements identified by PC 1st day of 1st quarter 39 months after notification by the PC**
 - **Or if Elements were identified in planning horizon outside of 39 month window then it will be 1/1/xx where xx would be that year beyond 2017 in the planning horizon**
- **R3 – If criteria 6,7,8,9,12,or 13 was used in R1 then coordinate calculated circuit capability with PC, TO, RC and all must agree on this calculated facility rating. (Same as R2 due dates)**

R6 (Due Date)

- For circuits 200 kV and below PC will conduct assessment yearly using criteria in attachment B to determine circuits in the planning coordinator area (due 1/1/2014) for which the TO,GO, DP must apply R1-R5. (due 4/1/2017 or 1/1/xx where xx is the year in the planning horizon outside the 39 month window)
- PC will maintain a list of circuits per application of attachment B
- PC will provide a list of circuits to RE, RC, TO, GO, and DP within its area within 30 days of the establishment of the final list.
 - Also provide updates within 30 days if changes are made to the list.

Update on R6 (PC List)

- **Transmission Working Group (TWG) meeting August 14th 2013**
 - **Initial list**
 - **Staff working with Nuclear units for B3 under Attachment B**
 - **TWG to review initial list**
 - **TWG to discuss coordination (list and B6 under attachment B)**
 - **List is due January 1st 2014**

PRC 023-3 Update

- **PRC 025-1, PRC 023-2 gap**
- **Relays not covered**
- **Example in PRC 025-1 Guidance and Technical Reference Document**

Example of Gap Radial

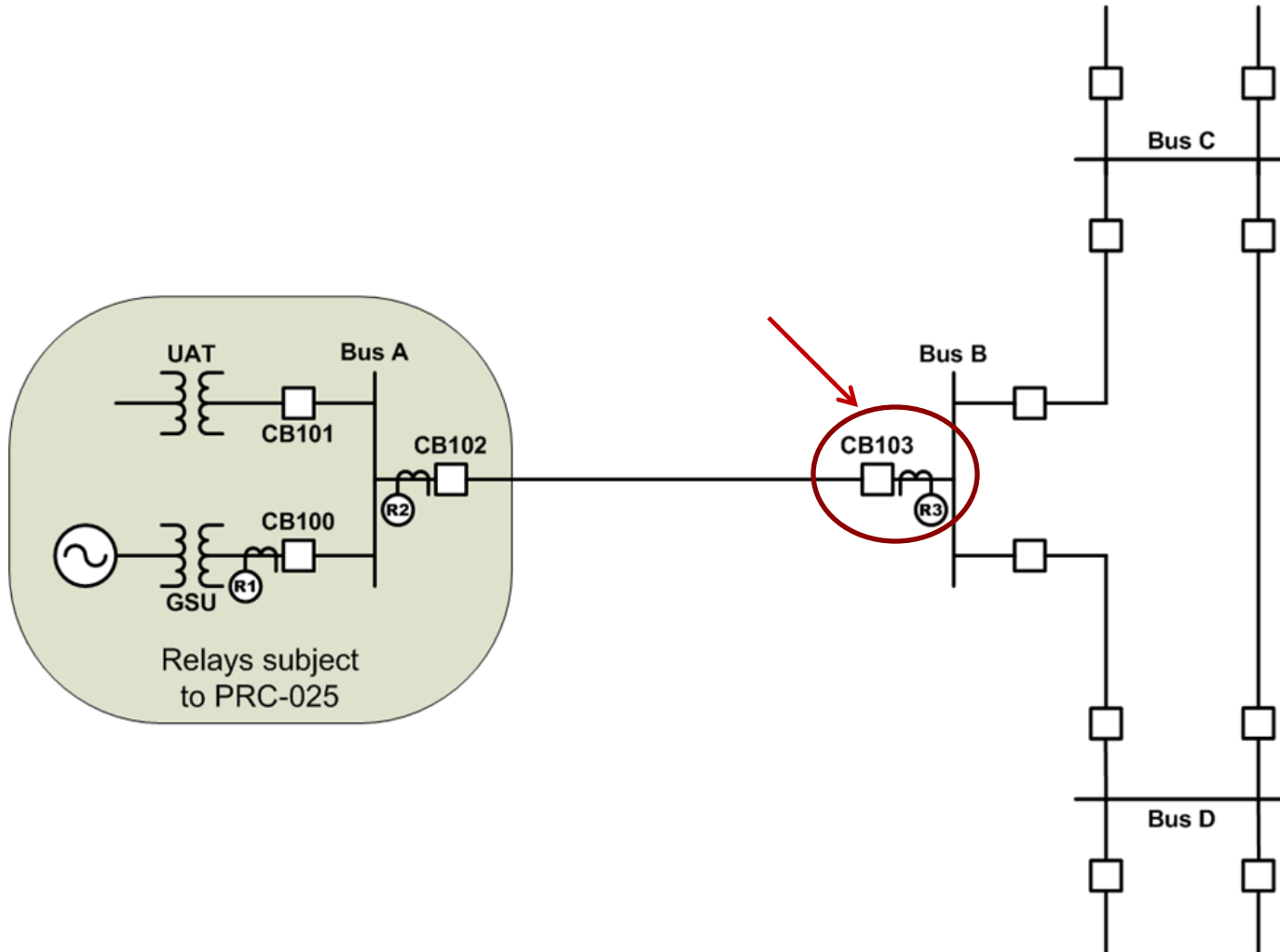

Example of Gap Parallel

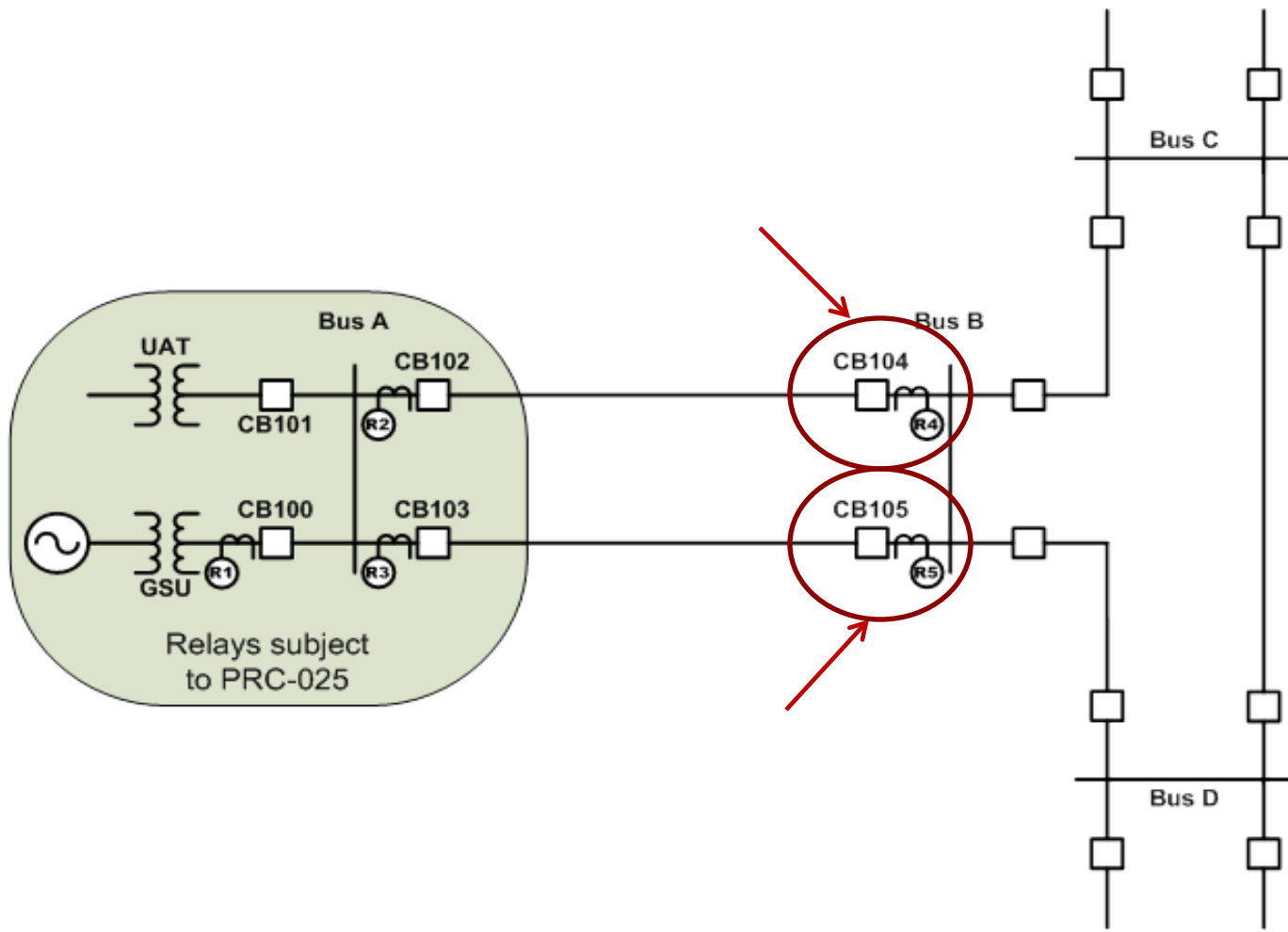

Considerations moving forward

- **Dates for when the existing requirements in PRC 023-1 fall off (listed in implementation Plan, provided link below)**
- **Coordination and time stamping of R6 list and transferred files between functional entities.**
- **Criteria for the analysis (Modified TPL assessment)**
- **Identifying Gap Relays and direction to determine applicability**

Questions ?????

- Contact compliance office
- Jonathan Hayes
 - jhayes@spp.org
 - 501-614-3509

Resources

- Presentation will be posted on [SPP.org/Compliance](https://www.spp.org/Compliance)
- [PRC 023-2 Standard](#)
- [PRC 023-3 Standard](#)
- [PRC 025-1 Standard](#)
- [PRC 025-1 Guidelines and Technical Basis Document](#)
- [SPCS Documents for relay loadability](#)
- [SPCS White paper Methods to increase line relay loadability](#)