

MARKETS



DEVELOPMENT UPDATE

February 2, 2022



*Working together to responsibly and economically
keep the lights on today and in the future.*



SouthwestPowerPool



SPPorg



southwest-power-pool



Southwest Power Pool
**WESTERN
ENERGY
SERVICES**

WELCOME AND OVERVIEW

BRUCE REW

AGENDA

Welcome and Overview	Bruce Rew
Stakeholder Process	Dustin Smith
Governance Design Team Update	Kara Fornstrom
Transmission Availability Design Team Update	Steve Johnson
Market Products/Price Formation Design Team Update	Jim Gonzalez
Next Steps	Bruce Rew
Open Discussion/Questions	Bruce Rew
Future Meetings	Bruce Rew

OVERVIEW: SPP STAKEHOLDER PROCESS

DUSTIN SMITH



Board of directors approves western RTO expansion terms and conditions.

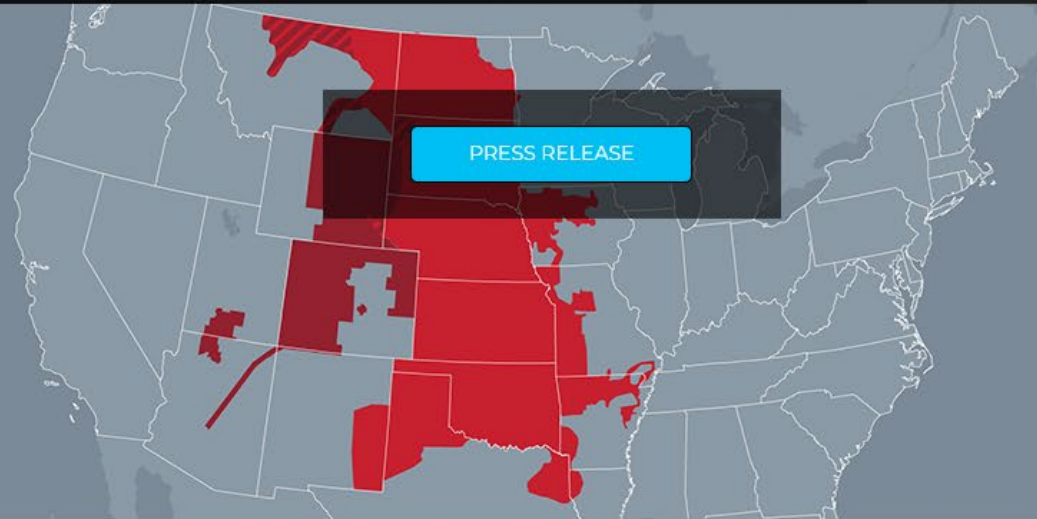

Working together to responsibly and economically keep the lights on today and in the future.

Price Contour Map

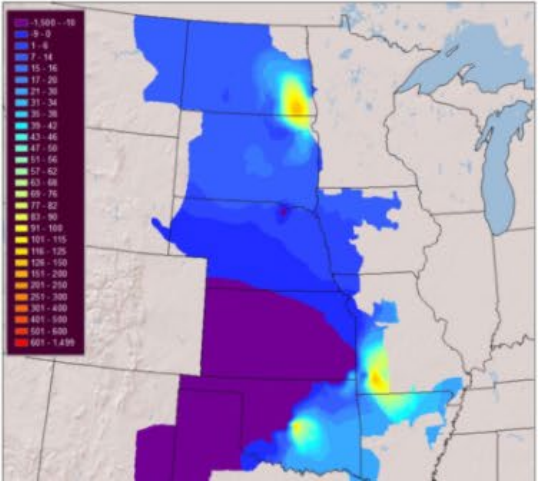

Generation Mix

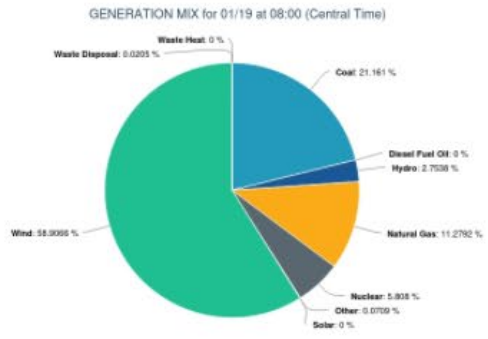

SEE MORE

Forecast vs. Actual

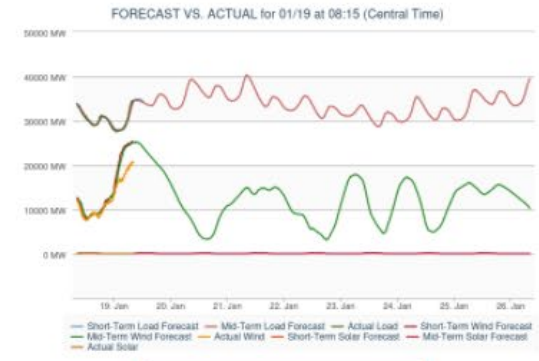

SEE MORE

STAKEHOLDER GROUPS

Select a committee, working group or task force listed below to view a complete summary. Each page contains an overview, roster and related documents. The [SPP Group Organizational Chart](#) lists SPP's groups and their respective chairs and secretaries.

To keep updated about SPP organizational group activities, subscribe to [The Org Report](#), a monthly e-newsletter that summarizes the groups' key activities. To subscribe, visit our [Exploder page](#), fill in the blanks and select Organizational Group E-Newsletter.

[ORGANIZATIONAL GROUPS](#) >

[ADVISORY GROUPS](#) >

[USER FORUMS](#) >

[WESTERN ENERGY SERVICES STAKEHOLDER GROUPS](#) ▼

- [Enhanced Curtailment Calculator Working Group](#)
- [Markets+ Development](#)
 - [Markets+ Governance Design Team](#)
 - [Markets+ Market Products and Price Formation Design Team](#)
 - [Markets+ Transmission Availability Design Team](#)
- [Qualified Owners and Operators](#)
 - [Unscheduled Flow Committee](#)
- [Western Markets Executive Committee](#)
 - [Western Markets Working Group](#)

STAKEHOLDER GROUPS

[ORGANIZATIONAL GROUPS](#) >

[ADVISORY GROUPS](#) >

[USER FORUMS](#) >

[WESTERN ENERGY SERVICES STAKEHOLDER GROUPS](#) >

[RETIRED GROUPS](#) >

MARKETS+ GOVERNANCE DESIGN TEAM

Markets+ Governance Design Team

Upcoming Events

[VIEW ALL](#)

Markets+ Governance Design Session

LOCATION:

TIME: April 04, 2022 12:00PM - 1:30PM

REGISTER:

Attending Through:

Markets+ Governance Design Session

LOCATION:

TIME: April 18, 2022 12:00PM - 1:30PM

REGISTER:

Attending Through:

Document Groups



Markets+ Governance
Design Team
Documents

QUICK LINKS

[ORGANIZATIONAL GROUPS](#) >

[ADVISORY GROUPS](#) >

[USER FORUMS](#) >

[WESTERN ENERGY SERVICES STAKEHOLDER GROUPS](#) >

- Enhanced Curtailment Calculator Working Group
- **Markets+ Development**
 - **Markets+ Governance Design Team**
 - Markets+ Market Design Team
 - Markets+ Transmission Design Team
- Qualified Owners and Operators
- Western Markets Executive Committee
- Western Reliability Executive Committee

[RETIRED GROUPS](#) >

SPP board of directors approves **western RTO expansion** terms and conditions.

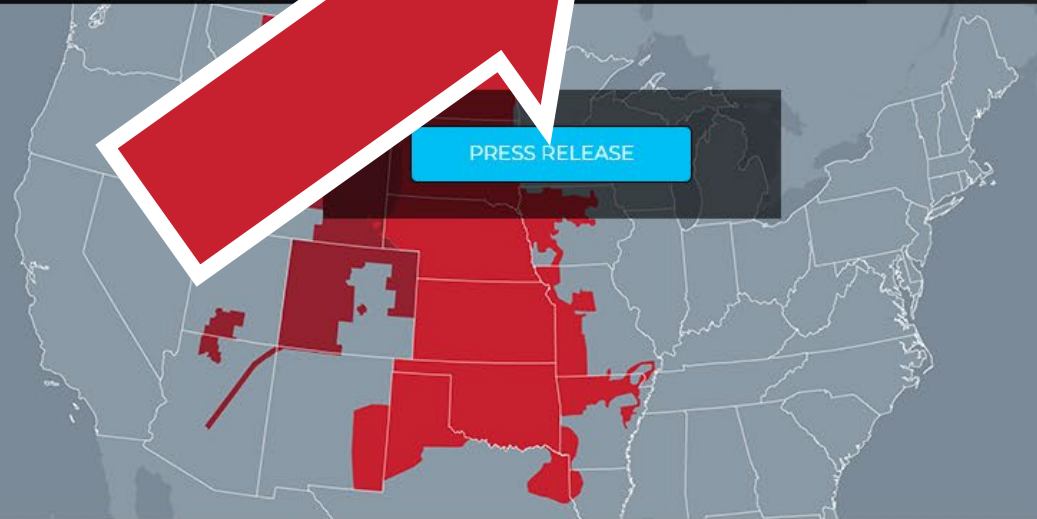

Working together to responsibly and economically keep the lights on today and in the future.

Price Contour Map

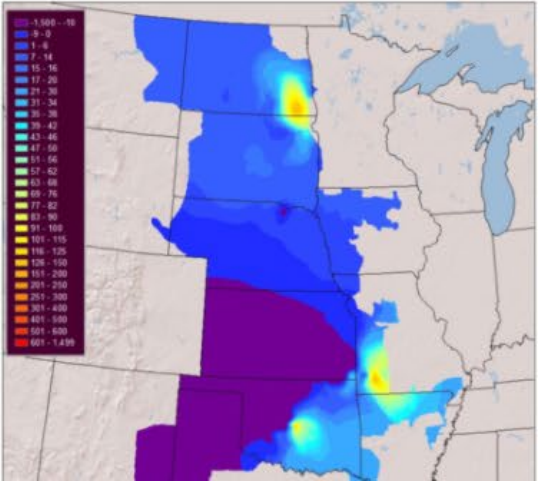

Generation Mix

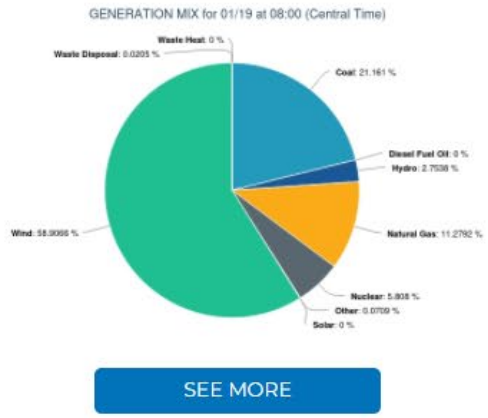

Forecast vs. Actual

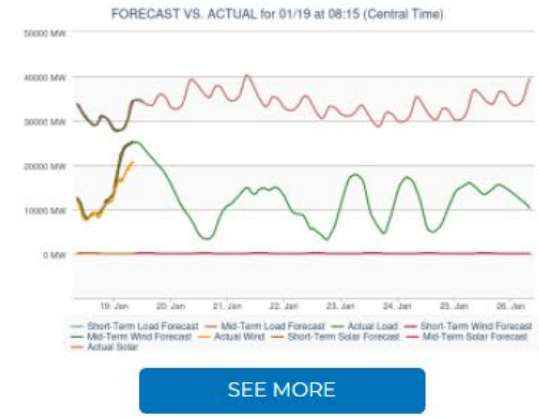

CREATE AN ACCOUNT

To register for events, fill out the form below:

First Name: *Enter First Name*
 Last Name: *Enter Last Name*
 Title: *Enter Your Title*
 Company: *Enter Company*
 Phone: *Enter Phone #*
 Email: *Enter Email*
 Email repeat: *Re-Enter Email*
 Address: *Enter Address*
 City: *Enter City*
 State/Province: *Alabama* **Postal Code:** *Enter Postal C...*
 Username: *Enter Username*
Dietary Restrictions:
 Vegetarian
 Vegan
 Gluten-Intolerant
 Shellfish
 Fish
 Egg
 Milk
 Nut
 Other
 User Type: *Choose...*
 Exploder Lists: *SPPMarkets+*

GOVERNANCE DESIGN TEAM UPDATE

KARA FORNSTROM

STAKEHOLDER LEADS

Sarah Edmonds	Director, Transmission Services	Portland General Electric
Aly Koslow	Director, Federal Regulatory Affairs and Compliance	Arizona Public Service
David Rubin	Federal Energy Policy Director	NV Energy
Joe Fina	Assistant General Counsel	Snohomish County Public Utility District No. 1
Lea Fisher	Senior Policy Analyst	Public Generating Pool

SPP Support Team

Kara Fornstrom	Director, State Regulatory Policy
Mike Riley	Associate General Counsel
Nicole Wagner	Manager, Regulatory Policy
Patti Kelly	Lead Regulatory Analyst

GOVERNANCE DESIGN TEAM

- Meeting Cadence:
 - Beginning Jan. 31, every other Monday
 - Starting at 10 a.m. Pacific, 11 a.m. Mountain, Noon Central
- Initial Topics
 - Operational Relationships
 - What are we governing?
 - How does Markets+ fit in with other Western services?
 - Foundational Components
 - SPP board of directors

WESTERN MARKETS ROADMAP

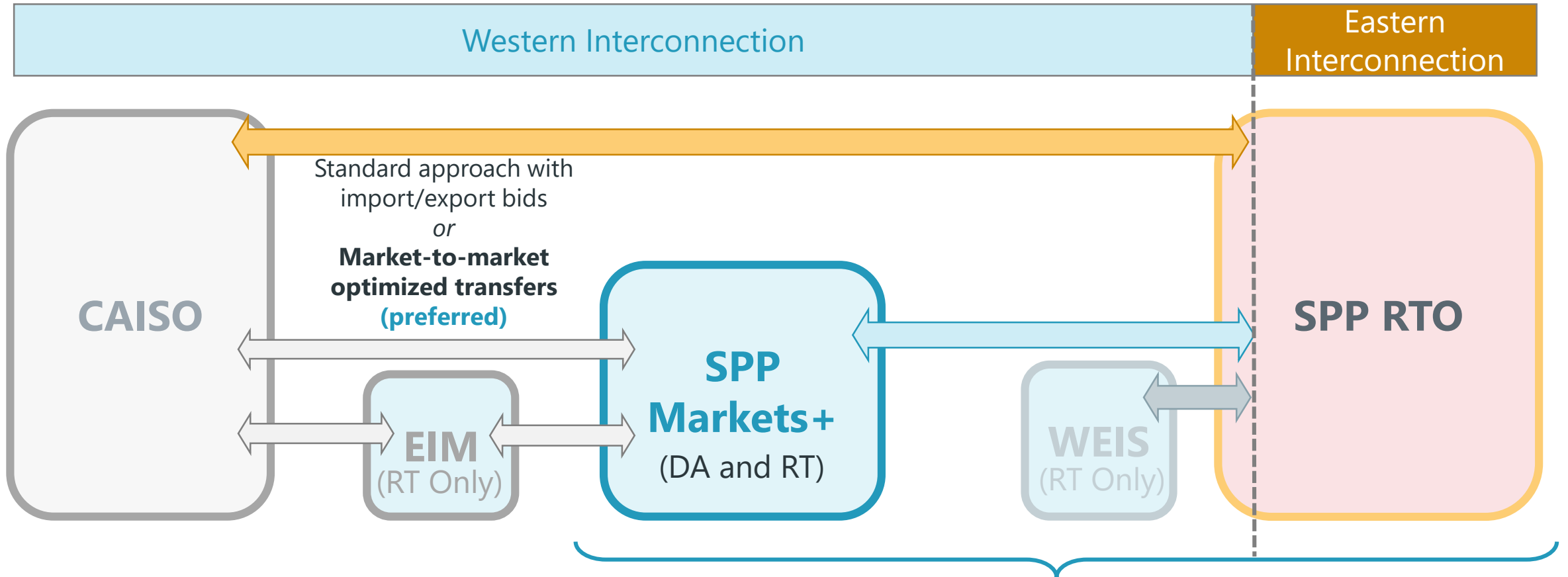

Ideally a single co-optimized unit commitment and dispatch under a robust governance framework with an independent board

TRANSMISSION AVAILABILITY DESIGN TEAM UPDATE

STEVE JOHNSON

TRANSMISSION AVAILABILITY DESIGN TEAM

- First Meeting 02/1/2022
 - Introduction to design team
 - Discussed scope/deliverable of first phase
 - Define principles and concepts as first step
- Plan to meet every four weeks
 - Next meeting Wednesday, Feb. 16 at 9 a.m. P; 10 a.m. M; 11 a.m. C
 - Coordinate with other groups, adjust as necessary

TRANSMISSION AVAILABILITY DESIGN TEAM

- Initial thoughts –
 - Maximize transmission available for market use (flow-based option preferred)
 - Honor existing OATT rights (value and priority)
 - Minimize cost shifts and freeridership
 - Minimize/eliminate market hurdle
 - Congestion rents will need to be added to discussion soon (coordination between transmission and market teams)
 - Make it simple, incent maximum participation

TRANSMISSION AVAILABILITY TEAM

STAKEHOLDER LEADS		
Joe Taylor	Manager, Transmission Access	Xcel Energy
Chris Hoffmann	Director Transmission & Generation Operations	Salt River Project
Mike Linn	Director, Market Analytics	Public Power Council

SPP Support Team	
Steve Johnson	Principal Operations Specialist
Hamilton Bitely	Senior Operations Analyst

MARKET PRODUCTS/PRICE FORMATION DESIGN TEAM UPATE

JIM GONZALEZ

MARKET PRODUCTS AND PRICE FORMATION DESIGN TEAM

STAKEHOLDER LEADS		
Jeff Spires	Director, Power	Powerex
Carrie Simpson	Director, Western Markets	Xcel Energy
Brian Cole	General Manager, Resource Management	Arizona Public Service
Russ Mantifel	Director of Market Initiatives	Bonneville Power Administration

SPP Support Team	
Jim Gonzalez	Manager, Real Time Markets
Gary Cate	Manager, Market Design

MARKET PRODUCTS AND PRICE FORMATION DESIGN TEAM

- First Meeting 02/1/2022
 - Introduction to design team
 - Define scope/deliverable
 - Begin discussions on key components for high-level market design
- Plan to meet every three weeks
 - Next meeting TBD, targeting week of 02/21/2022
 - Check and adjust

MARKET PRODUCTS AND PRICE FORMATION DESIGN TEAM

- Strategy
 - High-level design first
 - Concepts and lists
 - Frontload market design components with high consensus
 - Allow group to get comfortable with process
 - Give other groups time to make progress
 - Begin drafting offering language after general consensus on high-level design
 - Focus wordsmithing to as small a period as possible.

NEXT STEPS

BRUCE REW

Step 1

Step 2

Step 3

Step 4

Step 5

Seek interested parties
Information gathering

Distribute gathered feedback
Develop timeline and next steps
Develop detailed service offering

Conduct inclusive stakeholder process with committed parties

Obtain Board approval
Seek FERC approval

Launch



We are here

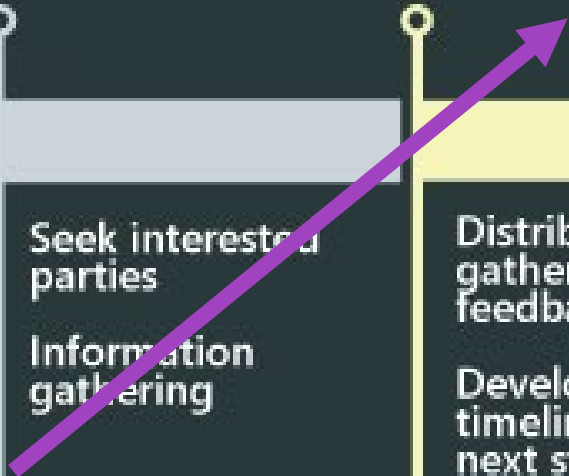

QUESTIONS & DISCUSSION

FUTURE MEETINGS

- February 14 – Governance Design Team
 - Every other Monday at 10 a.m. P; 11 a.m. M; Noon C
- February 16 – Transmission Availability Design Team
 - Every fourth Wednesday thereafter at 9 a.m. P; 10 a.m. M; 10 a.m. C
- March 2 – Development Update
 - Every fourth Wednesday at 9 a.m. P; 10 a.m. M; 11 a.m. C
- TBD – Market Products/Price Formation Design Team
- March 29-30 – In-Person Meeting

Questions or comments?

Contact us at:

marketsplus@spp.org

