

MARKETS



DEVELOPMENT UPDATE

March 29, 2022



*Working together to responsibly and economically
keep the lights on today and in the future.*



SouthwestPowerPool



SPPorg



southwest-power-pool



Southwest Power Pool
**WESTERN
ENERGY
SERVICES**

WELCOME AND OVERVIEW

BRUCE REW

SPP SR. VP, OPERATIONS

AGENDA

Welcome and Overview	Bruce Rew
Opening Remarks	Barbara Sugg
Participants Introductions	
SPP's Vision for Western Markets	Bruce Rew
Governance Design Team Update	Lea Fisher
JOINT Transmission Availability and Market Products/Price Formation Design Teams Update	Steve Johnson Jim Gonzalez
Questions/Discussion	
Meeting Goals and Expectations	Bruce Rew

OPENING REMARKS

BARBARA SUGG
SPP CHIEF EXECUTIVE OFFICER

PARTICIPANTS INTRODUCTION

SPP'S VISION FOR WESTERN MARKETS

BRUCE REW
SPP SR. VP, OPERATIONS



RTO West

- 7 organizations joining RTO in 2024; expected \$49M annual savings for new & existing members

Western Energy Imbalance Service (WEIS) Market

- Launched Feb. 2021; 3 new members joining in 2023 bringing load to 13.5GW

Markets+

- New real-time/day-ahead market in development with western parties (will replace WEIS)

Western Reliability Coordination Service

- Maintaining reliability for 13 western transmission operators

Western Interconnection Unscheduled Flow Mitigation Plan

- Helping western organizations manage grid congestion

Western Resource Adequacy Program Operator

- Partnering with Western Power Pool to ensure resource adequacy

Achieve
clean
energy
goals

Reinforce
system
reliability

Provide
economic
benefits

New
opportunities
to trade low-
cost power

Maintain
resource
adequacy

SPP'S MARKETS VISION

- WEIS continues for period of time
 - Imbalance market a great introduction to markets
 - Short-term solution for market participants
- RTO development
 - Provides long-term solution to market needs
 - Consolidated BA, Regional Planning, Unit Commitment
- Markets+ development
 - Possible long-term solution to meet some market needs

2022 MARKETS+ GOAL AND SCHEDULE

- Draft Service Offering – End of September
 - Written Comment Period
- Final Service Offering – Mid-November
 - Will Not Include: Market Protocols and Tariff Language
- Commitment to Investigate – Q1 2023
 - Financially Binding to Scope Implementation
- Stakeholder Process to Develop Market Protocols and Tariff Language
- Participant Agreement Execution – Fund Implementation

WESTERN MARKETS ROADMAP

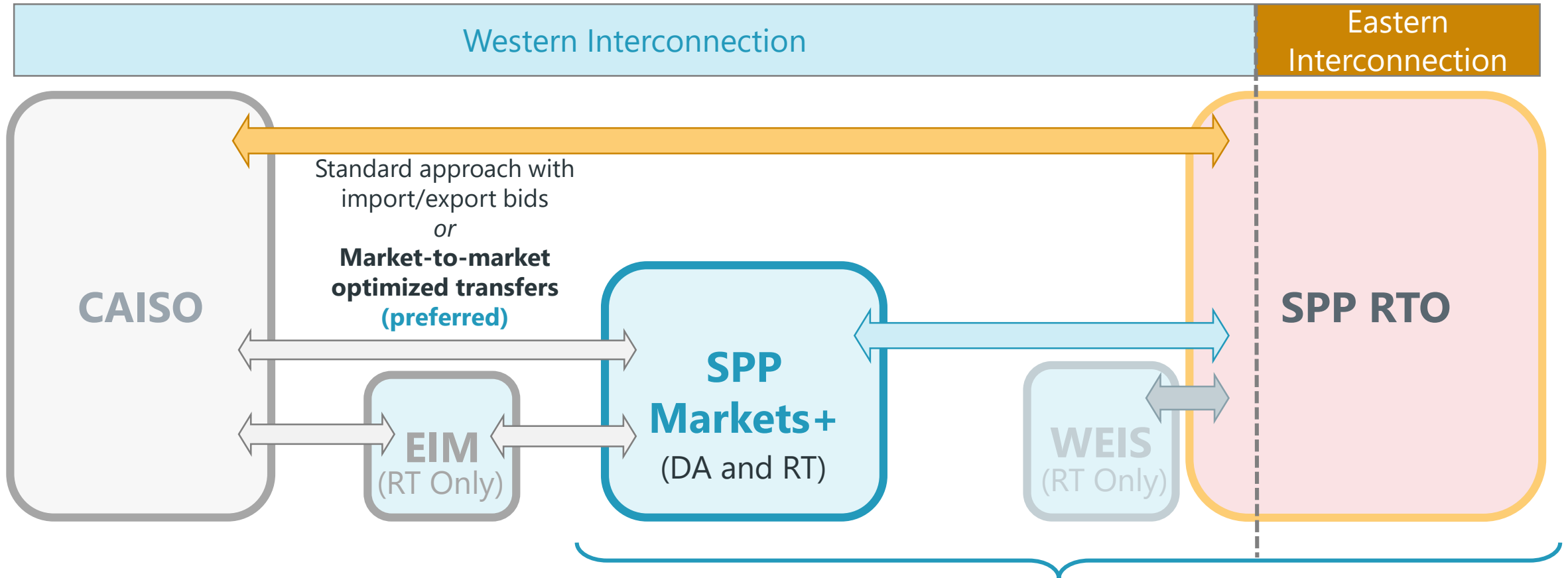

Ideally a single co-optimized unit commitment and dispatch under a robust governance framework with an independent board

GOVERNANCE DESIGN TEAM UPDATE

LEA FISHER, PGP

STAKEHOLDER LEADS

Sarah Edmonds	Director, Transmission Services	Portland General Electric
Aly Koslow	Director, Federal Regulatory Affairs and Compliance	Arizona Public Service
David Rubin	Federal Energy Policy Director	NV Energy
Joe Fina	Assistant General Counsel	Snohomish County Public Utility District No. 1
Lea Fisher	Senior Policy Analyst	Public Generating Pool

SPP Support Team

Kara Fornstrom	Director, State Regulatory Policy
Mike Riley	Associate General Counsel
Nicole Wagner	Manager, Regulatory Policy
Patti Kelly	Lead Regulatory Analyst

GOVERNANCE DESIGN TEAM PUBLIC WEBINARS

- January 31: Operational Relationships
- February 14: Topic Scope and Governance Objectives
- February 28: SPP Board of Directors and Western Contract Services Governance Frameworks
- March 14: Governance Options Introduction

GOVERNANCE OBJECTIVES

- Independent Board of Directors with Skills and Experience Reflective of All Regions, Market Participants and Interests within Its Oversight
- Open, Transparent Stakeholder Process that Balances Diverse Interests
- Board Nominating Process that is Clearly Defined and Geographically/Sector Representative
- Effective Forums for Stakeholders within the Governance Framework

MARKETS+ GOVERNANCE OPTIONS

2A

2B

Add 3?

SPP Independent Board

Markets+ Participants Executive Committee (MPEC) – Participant Based

Markets+ Working Group (M2WG) – Sector Based

Future Joint (with RTO) Work Groups

Markets+ State Committee

**Markets+ Independent
Governing Board**

**Nominating Committee
(Sector Based)**

**SPP By-Laws Modification
Board Qualifications?**

**SPP CGC
Add Markets+ Seat?**

MARKETS+ GOVERNANCE OPTIONS

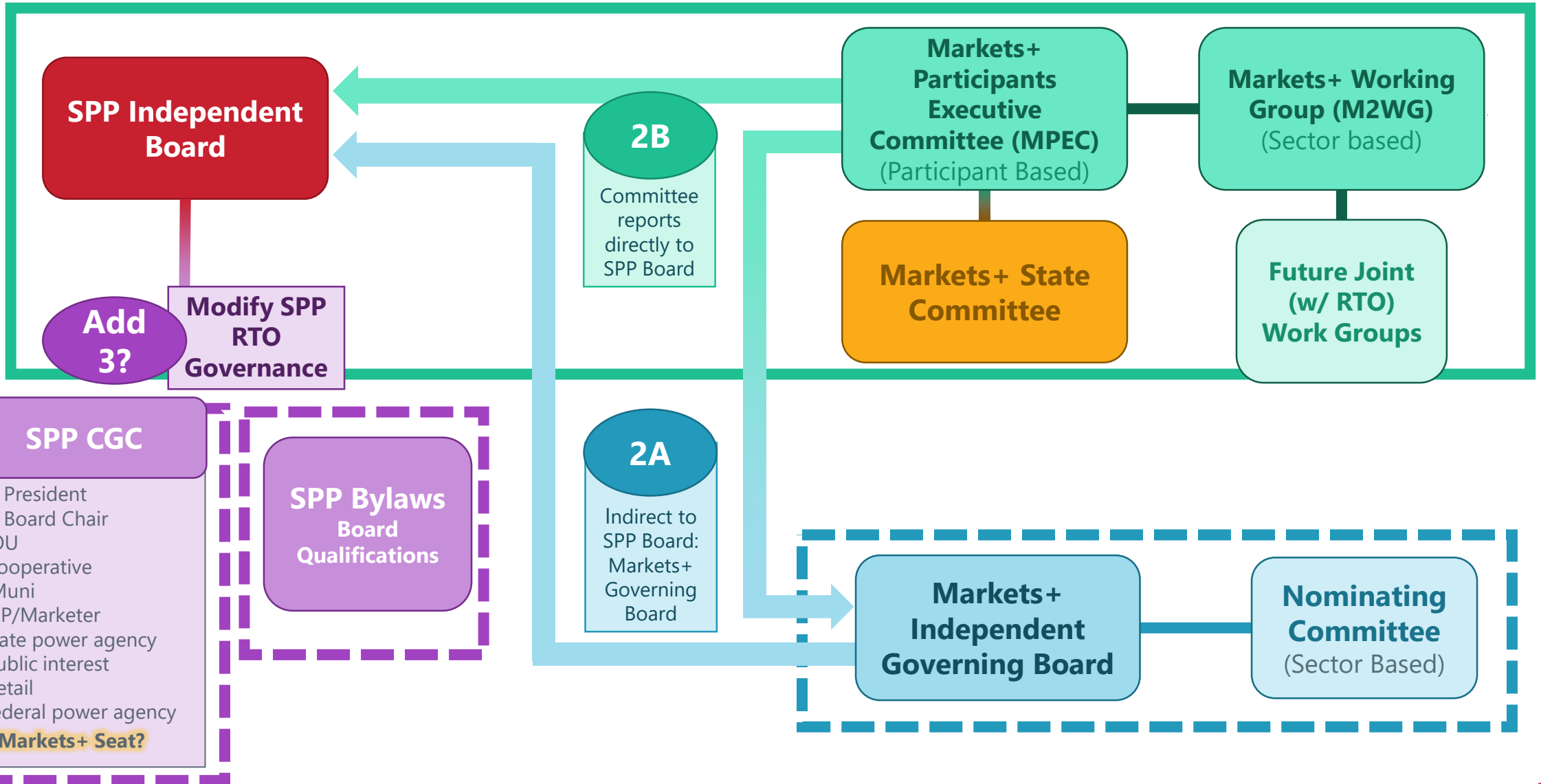

GDT FUTURE MEETINGS/SCHEDULE

- April 20: Written Comments Due
- April 25: Governance Design Team Webinar
 - Provide Summary of Written Comments
- April 27: Development Update Webinar
- May 23: Governance Design Team Webinar
 - Present Governance Concept Proposal
- June 1-2: In-Person Meeting - Denver

JOINT TRANSMISSION AVAILABILITY AND MARKET PRODUCTS/PRICE FORMATION DESIGN TEAMS UPDATE

STEVE JOHNSON, SPP PRINCIPAL OPERATIONS SPECIALIST

JIM GONZALEZ, SPP MANAGER, REAL TIME MARKETS

TRANSMISSION AVAILABILITY TEAM

STAKEHOLDER LEADS		
Joe Taylor	Manager, Transmission Access	Xcel Energy
Chris Hofmann	Director Transmission & Generation Operations	Salt River Project
Mike Linn	Director, Market Analytics	Public Power Council

SPP Support Team	
Steve Johnson	Principal Operations Specialist
Hamilton Bitely	Senior Operations Analyst

MARKET PRODUCTS AND PRICE FORMATION DESIGN TEAM

STAKEHOLDER LEADS		
Jeff Spires	Director, Power	Powerex
Carrie Simpson	Director, Western Markets	Xcel Energy
Brian Cole	General Manager, Resource Management	Arizona Public Service
Russ Mantifel	Director of Market Initiatives	Bonneville Power Administration

SPP Support Team	
Jim Gonzalez	Manager, Real Time Markets
Micha Bailey	Supervisor, Congesting Hedging

JOINT TADT/MPPF DESIGN TEAM MEETING

- First joint meeting on March 16th
 - Physical vs. Financial Transmission rights
 - Why the transition is needed
- Congestion Rents Options
 - Day ahead as imbalance market
 - Non-Auction based financial rights
 - Full ARR/TCR

JOINT TADT/MPPF DESIGN TEAM MEETING

- Bilateral Settlement Schedules (Financial Schedules)
 - Current tool in SPP tool box
- Base Schedules Discussion
 - Began discussion regarding application and function of Base Schedule concept
 - Seeking to understand if existing tools like Bilateral Settlement Schedules could facilitate Base Scheduling

QUESTIONS/DISCUSSION

MEETING GOALS AND EXPECTATIONS

BRUCE REW



Foster engaging discussions



Understand and give voice to diverse perspectives



Develop cohesive vision for Markets+

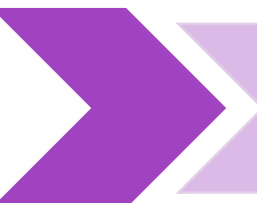

Recognize Markets+ role in benefitting market evolution in the Western Interconnection



Enjoy personal interaction and Have Fun!

TODAY'S SCHEDULE

- 9:45-10:00
- 10:00-12:00
 - Governance - Ocotillo
 - Transmission – Desert Star
 - Market Products – Larkspur
- 12:00-1:00
- 1:00-3:00
 - Governance – Desert Star
 - Joint Transmission/Market - Ocotillo
- 3:00-3:15
- 3:15-5:00
- 5:00-6:30

Break

Breakout Sessions

Lunch

Breakout Sessions

Break

Breakout Sessions

Reception SRP

TOMORROW'S SCHEDULE

- 7:30-8:00 Continental Breakfast
- 8:00-9:30 Breakout Sessions
 - Governance – Desert Star
 - Joint Transmission/Market - Ocotillo
- 9:30-9:45 Break
- 9:45-12:00 General Session
 - Design Team Readouts
 - Questions/Discussion
 - GHG Design Element
 - Next Steps/Schedule

MARKETS



DEVELOPMENT UPDATE

March 29, 2022



*Working together to responsibly and economically
keep the lights on today and in the future.*



SouthwestPowerPool



SPPorg



southwest-power-pool



Southwest Power Pool
**WESTERN
ENERGY
SERVICES**